

CBCT

programmable DC power supply



Vanguard Instruments Company, Inc.
www.vanguard-instruments.com

CBCT

programmable DC power supply



The Vanguard Circuit Breaker Coil Tester (CBCT) is a variable voltage DC power supply designed specifically to test substation circuit-breaker Open and Close coils. The CBCT uses the substation's DC power supply to electronically generate a programmable output voltage from 5% to 95% of the source voltage. The CBCT can maintain up to an 80A test current while maintaining 2% or better voltage regulation during the circuit breaker coil operation. The CBCT provides a safe and convenient method for testing minimum operating voltages of Open and Close coils.

The CBCT provides one pulse and one continuous DC output. The unit's builtin short-circuit protection feature protects the coil under test if the current exceeds 80 amperes or if the current drawing duration is more than 500 milliseconds. A general purpose single channel timer is also available for checking circuit breaker operating time or for any other timing application.

Input Voltage

The CBCT's input voltage range is from 20 to 300 Vdc. The input circuit is also protected from a reversed polarity connection.

Output Voltage

The output voltage is programmable from 5% to 95% of the input voltage and is set using the dial on the front panel. Output voltage regulation is better than 2% under load. Two DC outputs (one continuous and one pulse) are available on the CBCT. Both outputs are capable of sourcing up to 80 amperes. These outputs are protected against short-circuit conditions and will not exceed 80 amperes or a duration of 500 milliseconds.

CBCT Status Display

The CBCT features a back-lit LCD screen (20 characters by 4 lines) that is viewable in both bright sunlight and low-light levels. The input and output voltages are displayed on the screen during testing. If a power supply fault condition occurs, a red "FAULT" LED light is illuminated on the front panel and a corresponding message is displayed on the LCD screen.

CBCT Timer

The built-in, single channel timer can be used to verify circuit-breaker timing parameters or for any timing application. The timing range is from 0.000 to 999.000 seconds with an accuracy of 0.1 milli-seconds. The timing results are displayed in both milli-seconds and cycles. The timer can be started by circuitbreaker coil initiation or can be triggered by the dry or wet contact input. The timer can be stopped by either the dry or wet contact input.

CBCT connections

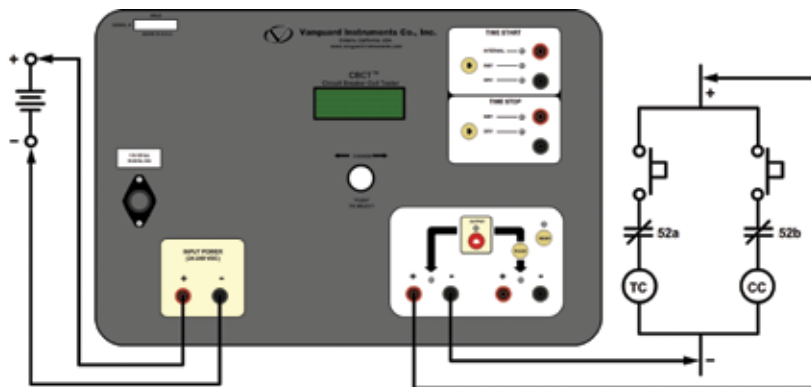

ordering information

Part number **CBCT**

CBCT circuit breaker coil tester, cables

CBCT Controls & Indicators

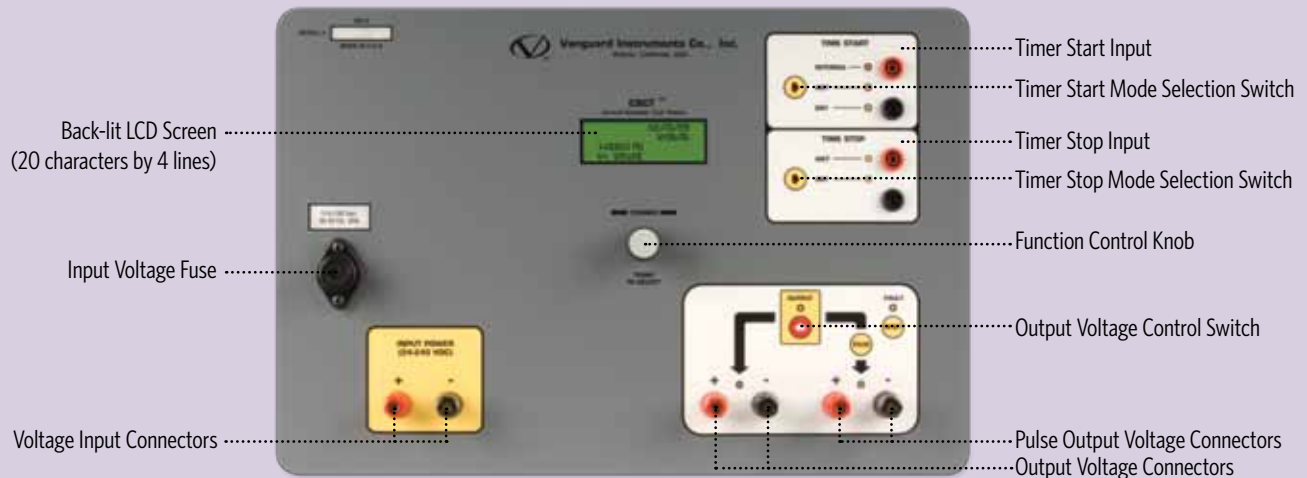

CBCT specifications

type	portable test equipment, programmable DC power supply
physical specifications	19"W x 7"H x 15"D, (48 cm x 17 cm x 38 cm); Weight: 25 lbs (11.3 kg)
input voltage	20 – 300 Vdc, 20A fuse
output voltages	5% – 95% of input voltage with 2% regulation at max current (up to 80A)
output voltage channels	one continuous and one pulse DC output
output voltage protection	shutdown if current exceeds 80A or if current drawing time exceeds 500 ms @ 80A
volt meter range	input/output meters, 0 – 300 Vdc; Accuracy: 1% of reading, $\pm 0.2V$
timer display range	0.0000 – 999.999 seconds; Accuracy: 0.1 ms, ± 1 digit
timer start input	internal (coil initiation), wet-contact input (20 – 240 Vac/dc), or dry-contact input (1 – 200 ohms)
timer stop input	wet-contact (20 – 240 Vac/dc) or dry-contact (1 – 200 ohms)
display	back-lit LCD screen (20 characters by 4 lines); viewable in both bright sunlight and low-light levels
safety	designed to meet UL 61010A-1 and CAN/CSA C22.2 No. 1010.1-92 standards
environment	Operating: $-10^{\circ}C$ to $+50^{\circ}C$ ($+15^{\circ}F$ to $+122^{\circ}F$); Storage: $-30^{\circ}C$ to $+70^{\circ}C$ ($-22^{\circ}F$ to $+158^{\circ}F$)
humidity	90% RH @ $40^{\circ}C$ ($104^{\circ}F$) non-condensing
altitude	2,000 m (6,562 ft) to full safety specifications
cables	two 6-foot (1.83m) #8 AWG DC cable sets, two 10-foot (3.05m) cable sets, one ground cable, one cable bag
options	transportation case
warranty	one year on parts and labor

NOTE : the above specifications are valid at nominal voltage and ambient temperature of $+25^{\circ}C$ ($+77^{\circ}F$). Specifications are subject to change without notice.



Instruments designed and developed by the hearts and minds of utility electricians around the world

Vanguard Instruments Company, (VIC), was founded in 1991. Currently, our 28,000 square-foot facility houses Administration, Design & Engineering, and Manufacturing operations. From its inception, VIC's vision was, and is to develop and manufacture innovative test equipment for use in testing substation EHV circuit breakers and other electrical apparatus.

The first VIC product was a computerized circuitbreaker analyzer, which was a resounding success. It became the forerunner of an entire series of circuitbreaker test equipment. Since its beginning, VIC's product line has expanded to include microcomputer-based, precision micro-ohmmeters, single and three phase transformer winding turns-ratio testers, transformer winding-resistance meters, mega-ohm resistance meters, and a variety of other electrical utility maintenance support products.

VIC's performance-oriented products are well suited for the utility industry. They are rugged, reliable, accurate, user friendly, and most are computer controlled. Computer control, with innovative programming, provides many automated testing functions. VIC's instruments eliminate tedious and time-consuming operations, while providing fast, complex, test-result calculations. Errors are reduced and the need to memorize long sequences of procedural steps is eliminated. Every VIC instrument is competitively priced and is covered by a liberal warranty.



Vanguard Instruments Company, Inc.

1520 S. Hellman Avenue • Ontario, California 91761, USA
Phone 909-923-9390 • **Fax** 909-923-9391
www.vanguard-instruments.com